

Basic Compressor/Limiter Design

Abstract

THAT Corporation's 2252 RMS-Level Detector and 2180/2181 Series Voltage-Controlled Amplifiers (VCAs) are ideal basic building blocks for compressor/limiter designs. This application note describes in detail the circuitry for two basic compressor/limiter designs using these devices.

The first design is an above-threshold, hard-knee compressor with variable ratio, threshold and gain controls. The second design adds a soft-knee threshold. Suggestions for alignment are presented, as are ideas for modifying the basic circuits to allow common variations.

Basic Compressor/Limiter Design

This application note describes how to use THAT Corporation's 2252 RMS-Level Detector and 2180 / 2181 Series Voltage-Controlled Amplifiers to make basic above-threshold compressor/limiters. Throughout the text, it is assumed that the reader has become familiar with the basic application of these devices. For additional information on the operation of the devices themselves, please refer to the 2252 and 2180 / 2181 Series data sheets.

A THAT 2252 RMS-Level Detector and 2180 / 2181 Series Voltage-Controlled Amplifier (VCA), makes an ideal detector/controller pair for audio compressor/limiter designs. The 2252 provides a dc output in logarithmic (decibel-scaled) format, while a 218X (2180A / 2181A, 2180B / 2181B and 2180C / 2181C) accepts gain control commands in exponential format (also decibel-scaled). The combination of a 2252 detector and a 218X VCA makes it possible to construct a variety of compressors and/or limiters with unprecedented ease, freeing the design engineer to concentrate on the functional requirements of a design, rather than on the methods to achieve this functionality.

Above-Threshold Compressor

Figure 1, Page 2, shows a basic above-threshold compressor utilizing a 2252 detector and a 218X VCA. This design offers independent control over threshold, compression ratio, and after compression gain. Time constants are handled "automatically" by the 2252. The design exploits the highly predictable behavior of the 2252 and 218X to make possible a simple, effective and versatile

feedforward approach to gain control. (For a mathematical analysis of this class of circuit, see AN101A, *The Mathematics of Log-Based Dynamic Processors*, also available from THAT Corporation.)

Signal Path

The audio signal flows only through the 218X and OA₁, making the signal path short enough to locate it entirely around the input and output jacks on the PC board. Input signals are coupled to the 218X through C₁ and R₁. Since the input of the 218X is a virtual ground, R₁ determines the strength of the input (current) to the 218X. The 20k resistor shown is optimum for input voltages of up to about 10 V_{RMS}, or +20 dBV.

C₁ (along with R₁) sets the low-frequency limit in the signal path ($f_c = \frac{1}{2\pi R_1 C_1}$). As shown, the -3 dB corner is at about 0.8 Hz.

The 218X produces an output current signal in pin 8 which is a replica of the input signal, scaled (in decibels) by the voltage at pin 3. OA₁ converts this current back to a voltage based on its feedback resistor, R₆. For R₁ = R₆, as shown, V_{IN} = V_{OUT} whenever pin 3 (the control port) is at 0 V (this is unity, or 0 dB gain). For every 6 mV increase in the voltage at pin 3, the gain *decreases* by 1 dB. For every 6 mV decrease in voltage, the gain *increases* by 1 dB. Therefore, the output signal level depends only on the input signal and the control voltage applied to pin 3.

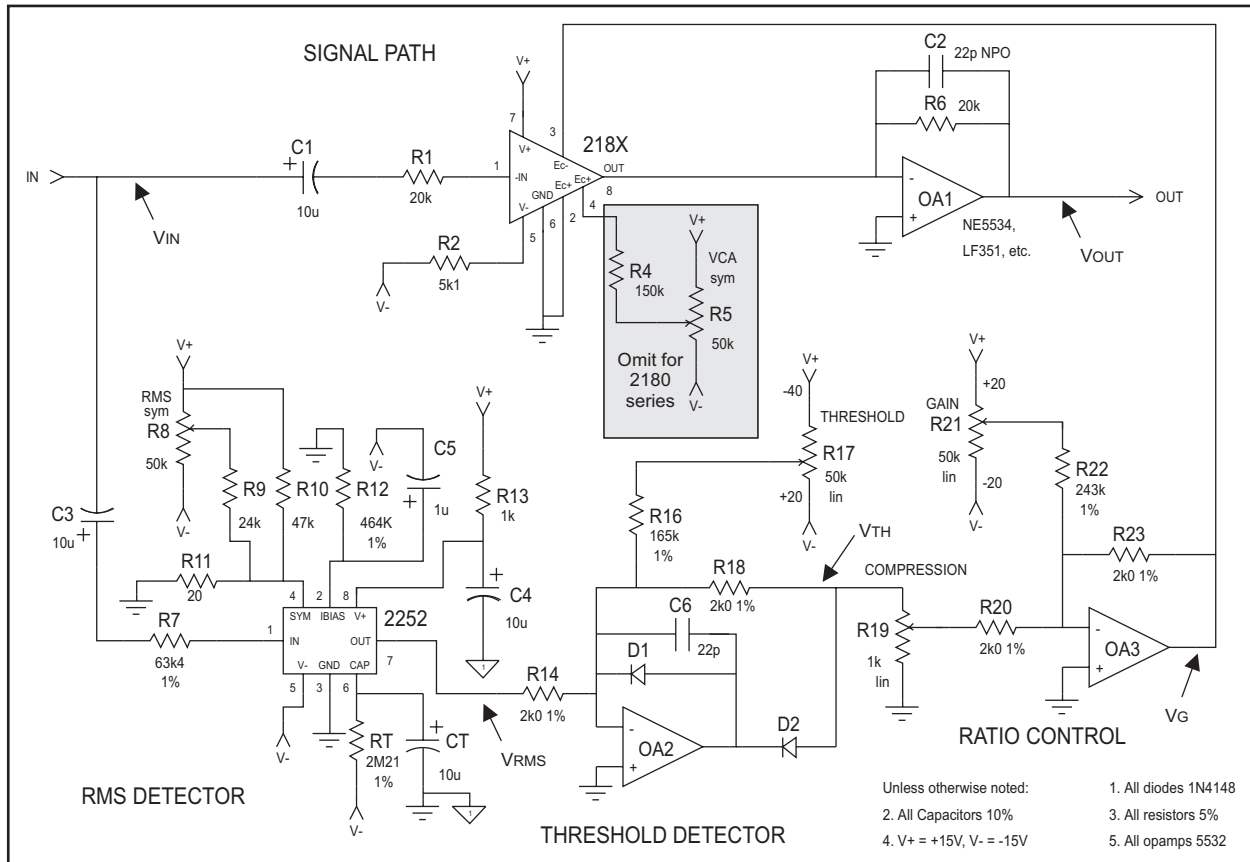

Figure 1. Basic Above-Threshold Compressor/Limiter

RMS-Level Detector

The input signal is also applied to the 2252 rms detector through C_3 and R_7 (like the 218X, the 2252's input is a virtual ground). In this circuit, the 2252 is configured to provide 0 V at its output (pin 7) when approximately 316 mV rms (-10 dBV) is present at the circuit input. As the input signal varies, the 2252's output voltage will vary. For each 1 dB of increase in input level, its output increases by 6 mV. Every 1 dB decrease in input causes a 6 mV decrease in dc output.

Adjusting the Threshold

The output of the 2252 is connected to OA_2 , which is configured as an inverting, half-wave operational rectifier. Neglecting the effect of R_{16} and R_{17} , when V_{RMS} is negative, the output of OA_2 will be positive, and D_2 blocks this voltage from reaching V_{TH} . Therefore, $V_{TH} = 0$ for $V_{RMS} < 0$. However, when V_{RMS} is positive, the output of OA_2 goes negative, and V_{TH} follows V_{RMS} with a gain of -1. Therefore, $V_{TH} = -V_{RMS}$ for $V_{RMS} > 0$ V.

Neglecting the effects of R_{16} and R_{17} , OA_2 and its associated circuitry only passes information when the input signal is above the input level which causes $V_{RMS} = 0$ V (the *threshold*). No information passes for signals

below this threshold. The transition from below to above threshold is sharp, because the operational rectifier used as the threshold detector linearizes the diode's exponential V-I characteristic.

R_{17} and R_{16} provide a means of adjusting the threshold. For supply rails of ± 15 V, R_{17} adjusts the threshold over ± 182 mV (from $\frac{(V+)R_{18}}{R_{16}}$ to $\frac{(V-)R_{18}}{R_{16}}$), equivalent to ± 30 dB at 6 mV/dB. With the wiper of R_{17} towards $V+$, V_{TH} will respond for any $V_{RMS} > -182$ mV, or $V_{IN} > -40$ dBV. With the wiper of R_{16} towards $V-$, V_{TH} will respond for $V_{RMS} > +182$ mV, or $V_{IN} > 20$ dBV. This adjusts the threshold over the range +20 dBV to -40 dBV.

Note that a linear-taper potentiometer should be used for R_{17} , the THRESHOLD control. This is because the signal at the 2252 output represents the log of the input signal level — it has already been converted to decibels. A linear change in threshold voltage corresponds to a linear change in decibel threshold.

V_{TH} therefore represents the decibel level of the input signal above THRESHOLD. See Figure 2, Page 3 for

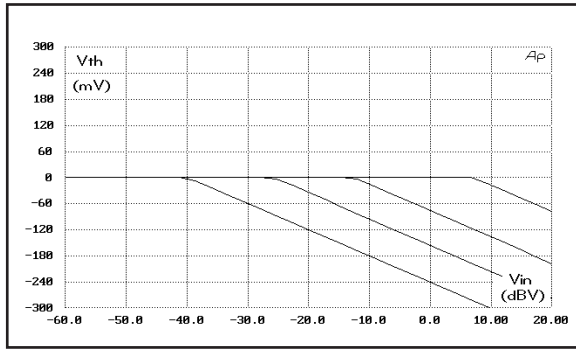

Figure 2. VTH vs. VIN for various THRESHOLD settings.

a plot of V_{TH} versus V_{IN} , with various settings of the THRESHOLD control.

Adjusting Compression

R_{19} , the COMPRESSION control, allows the user to scale V_{TH} before it is passed on to the rest of the circuitry. Neglecting the action of R_{21} and R_{22} , when the wiper of R_{19} is at its ground end, no signal is passed on to OA_3 . When the wiper is at the opposite end (the maximum), the output of OA_3 (V_G) exactly mirrors V_{TH} . For settings in between, V_G will be a mirror image of some fraction of V_{TH} , with the fraction determined by the setting of the COMPRESSION control.

When COMPRESSION is at maximum, $V_G = V_{TH}$, so V_G in turn represents V_{IN} above threshold at 6mV/dB. But, V_G is applied to pin 3 of the 218X VCA, which controls gain at the rate of -6 mV/dB. For every 1 dB increase in V_{IN} (above threshold), V_G increases by 6 mV, and the gain of the VCA decreases by 1 dB. Therefore, at maximum COMPRESSION, the signal gain decreases in exact proportion to signal level increases above threshold, preventing any increase in output level above the threshold.

For intermediate settings of the COMPRESSION control, the decrease in signal gain is proportional to, but less than, the increase in signal level above threshold. For example, at the electronic halfway point for R_{19} , signal gain will decrease by 0.5 dB for each 1 dB increase in input signal above threshold. This will result in an increase in output signal of 0.5 dB for each 1 dB increase in input signal.

The *Compression Ratio* is a measure of the increase in output signal for increases in input signal above threshold. It is defined as $RATIO = \frac{\Delta V_{IN}}{\Delta V_{OUT}}$, where ΔV_{IN}

is the decibel change in input signal and ΔV_{OUT} is the decibel change in output signal. The compression ratio is $\infty:1$ when the COMPRESSION control is at its maximum, and 1:1 at its minimum. For settings in between, the ratio is determined by the setting of R_{19} ,

taking into account the loading effect of R_{20} . If the electrical setting of the COMPRESSION control is expressed as a ratio R relative to full scale (i.e., maximum is 1.0, 50% of full scale is 0.5, etc.), then the compression ratio is determined by the setting of the COMPRESSION control as follows: $RATIO = \frac{1}{1-R}$.

In the circuit shown, 2:1 compression will occur at slightly more than the halfway point in the pot's rotation, due to the loading of R_{20} . It is not uncommon in this sort of design to add a resistor between the top of R_{19} and its wiper, in order to set 4:1 compression at the 50% rotation point. (Approximately 250 Ω would be right.)

Figure 3, Page 3, plots V_G versus V_{IN} , for several settings of the COMPRESSION control, at a fixed THRESHOLD setting.

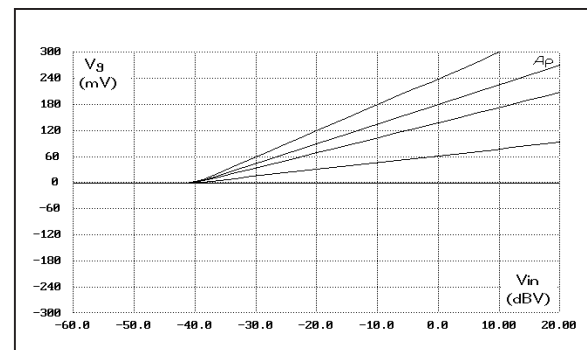

Figure 3. VG vs. VIN for various COMPRESSION settings.

Adjusting Gain

The action of R_{21} and R_{22} , neglected in the foregoing analysis, is to add a dc offset to the gain control voltage, V_G . This causes a static gain or loss in the signal path, at the familiar constant of 6 mV/dB. As shown, with ± 15 V supply rails, varying R_{21} (the GAIN control) will cause V_G to vary over ± 123 mV. This corresponds to approximately ± 20 dB of gain change. This variation is useful in making up for level lost during compression. Figure 4, Page 3, plots V_G vs. V_{IN} for various set-

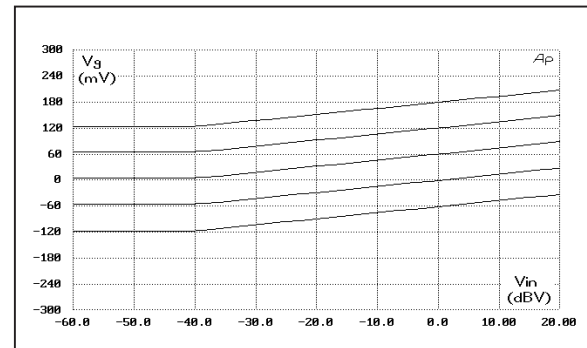

Figure 4. VG vs. VIN for various GAIN settings

tings of the GAIN control, at constant COMPRESSION and THRESHOLD settings.

Resulting Compression Characteristic

The circuit of Figure 1 produces a family of input vs. output characteristic curves as shown in Figure 5, Page 4. Note that the onset of compression (the bend in the curves) is sharp, deriving from the sharp rectification characteristic of the operational rectifier used in the threshold detector. Also note the similarity of the previous curves showing control voltages versus V_{IN} to the plots of V_{OUT} vs. V_{IN} . This follows from the fact that the 2252 produces a decibel representation of the input signal, and that the 218X responds directly to decibel gain commands.

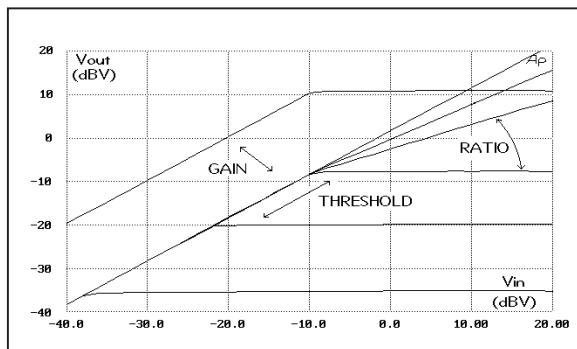

Figure 5. V_{IN} vs. V_{OUT} for various Control Settings

Trim Adjustments

Two trim pots, R_5 and R_8 , are shown in Figure 1. As described in the data sheets for the 2180/2181 Series VCAs and 2252 rms detector, these controls are used to adjust the symmetry of each part. R_5 is adjusted to minimize distortion and control feedthrough in a 2181 (but is not required for a 2180), and R_8 adjusts the symmetry of the full-wave rectifier within the 2252. When used within a compressor as shown in Figure 1, there are several methods which may be used to efficiently set these controls.

No matter what method is used, the objective is to adjust the VCA for low distortion (which coincides with low control feedthrough) and adjust the rms-detector for minimum ripple. If a thoughtful procedure is not followed, it is possible to misadjust one control to "make up" for a misadjustment in the other. Unfortunately, this only works for one frequency, level and control setting.

The waveform at pin 7 of the 2252 normally shows some ripple left by the single-pole filtering of the rms-level detector. The ripple is larger, and therefore easier to observe, at low frequencies. The preferred method of adjustment is to apply a 100 Hz, 300 mV

sinewave to the signal input, and probe pin 7 of the 2252 (V_{RMS}) with an oscilloscope. Adjust R_8 for minimum ac signal, which yields a symmetrical, 200 Hz sinusoid.

Next, apply a 1 kHz, 1 V sine wave to the input of the compressor. The COMPRESSION control should be at minimum (towards ground), the THRESHOLD control should be at maximum (towards V+), and the GAIN control should be at its midpoint. Observe the output waveform with a THD meter, and adjust R_5 for minimum THD.

Another method, which eliminates the need to probe the output of the 2252, is to apply a 1 kHz, 1 V signal to the input of the circuit. Set the COMPRESSION control to minimum (towards ground), the THRESHOLD control to maximum (towards V+), and the GAIN control to its mid-point. This prevents ripple from the 2252 from reaching pin 3 of the 218X, and allows the technician to adjust the VCA symmetry in effective isolation. Adjust R_5 for minimum THD at the signal output.

Next, change the input signal to a 1 V, 100 Hz sine wave. Set the COMPRESSION control to maximum, the THRESHOLD control to minimum, and the GAIN control to its maximum (towards V+). This produces approximately 20 dB of compression from the circuit, and introduces additional distortion due to ripple in the 2252 output. Now adjust R_8 for minimum THD at the signal output. When the rectifier is adjusted for proper symmetry, ripple in the 2252 output is minimized, as is distortion in the entire system.

Time Constants

The time constants of the compressor shown in Figure 1 are entirely determined by the 2252 and choice of its timing components, C_T and R_T . As shown, the integration time of the 2252 is set to approximately 30 ms, appropriate for most audio applications. For certain applications, however, it may be desirable to vary this. Simply changing the value of C_T will scale the integration time proportionately, and is conceptually the easiest way to alter timing. Changing the value of R_T will affect level match as well as the time constants (see the 2252 data sheet for details).

More elaborate variations in time constants are also possible. This topic will be covered in a forthcoming application note. For more detail about the time constants in RMS-based compressor limiters, see Audio Engineering Society Preprint number 4054, *Attack and Release Time Constants in RMS-Based Compressors and Limiters*, by Fred Fluor.

Higher (or Lower) Input Levels

1.5 mA is the maximum recommended signal current ($I_{IN} + I_{OUT}$) for a 218X. (I_{IN} is the input signal cur-

rent, I_{OUT} is the output signal current.) The I_{OUT} which corresponds to a given I_{IN} will be determined by the control settings, but the maximum I_{OUT} is likely to be several dB lower than the peak I_{IN} due to the compressor action. A reasonable assumption is that the peak I_{OUT} is 6 dB less than the peak I_{IN} . In that event, for $I_{IN} + I_{OUT} = 1$ mA, $I_{IN} = 1$ mA and $I_{OUT} = 500$ μ A.

With the values shown for R_1 and R_6 , 1 mA of input current will flow when the input signal reaches 20 V_{RMS} (+26 dBV). To accommodate higher input voltages, R_1 should be scaled larger. Where the maximum input signal will never approach +26 dBV, R_1 (and R_6) may be reduced proportionately, obtaining a commensurate improvement in signal-to-noise ratio.

Soft-Threshold Compressor

The preceding basic above-threshold compressor design may be easily altered to suit different applications. One common variation is to provide a "soft knee" in the compression characteristic (see Figure 9, Page 6) for a look at this characteristic. The circuit of Figure 6, Page 5, will accomplish this.

In Figure 6, the operational rectifier used as the threshold detector in Figure 1 has been replaced with an open-loop diode (D_2). A silicon diode such as the

1N4148 used in Figure 6 has an exponential V-I characteristic, requiring several tenths of a volt to switch from non-conducting to conducting. In the circuit shown, the effective resistance of D_2 will vary with the voltage at the output of OA_2 , from virtually infinite for negative voltages to tens of ohms at voltages approaching 700 mV. The variation produces a "sloppy" half-wave rectification of the 2252's output signal.

The range of voltages over which the D_2 provides useful variation in impedance is from about 300 mV to 600 mV, or about 300 mV in total. A 300 mV variation at the 2252's output represents approximately 50 dB variation in signal level — too much to be directly useful for the threshold region. Therefore, additional gain (OA_2 , R_{14} , R_{18} , etc.) has been provided to present D_2 with a larger voltage range, thereby sharpening the resulting threshold characteristic. The gain from V_{RMS} to V_{TH} reaches a maximum of approximately 1.8. (At 20 dB compression, D_2 has an impedance of 100 Ω .) R_{16} has been changed to produce the same threshold range as in the original circuit.

Figure 7, Page 6, plots V_{TH} vs. V_{IN} for the circuit of Figure 6 (with variations in THRESHOLD setting). Notice the gradual transition from 0 V output (no signal passing through) to positive signal output (passing V_{RMS} onwards). A sharper transition may be achieved

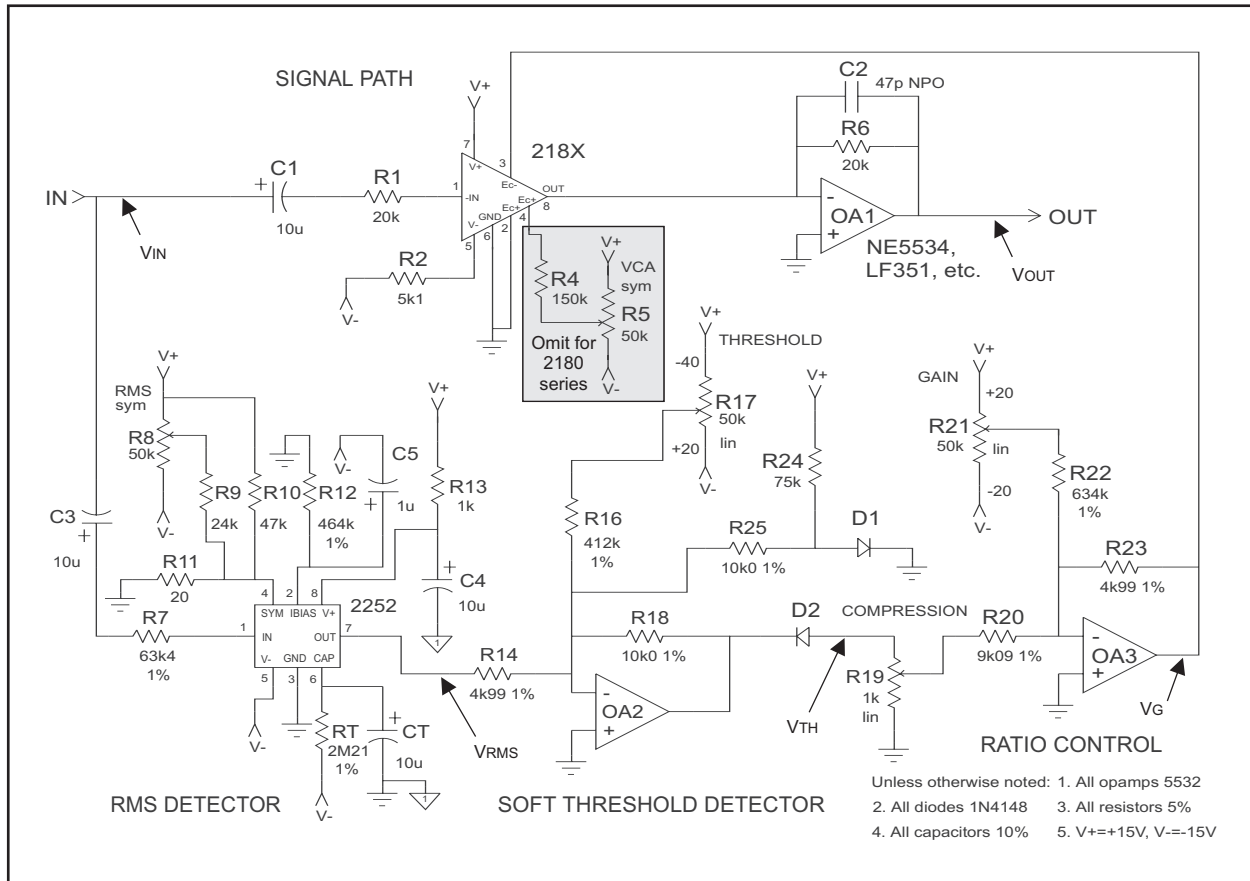

Figure 6. Basic Soft-Threshold Compressor/Limiter

by increasing the closed-loop gain of OA_2 while simultaneously reducing the closed-loop gain of OA_3 by the same ratio.

R_{24} , D_1 and R_{25} are included to provide temperature compensation for the forward voltage drop of D_2 . R_{24} sets up a current of approximately 130 μA through D_1 ,

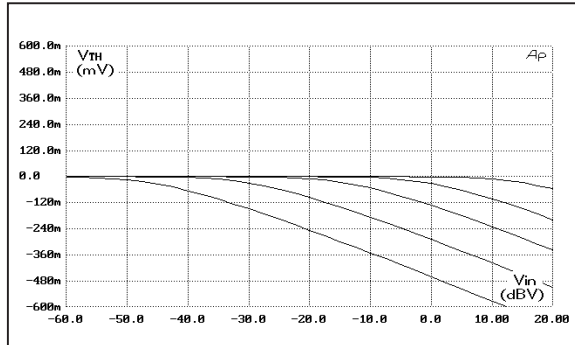

Figure 7. V_{TH} vs. V_{IN} for the Soft-Knee Circuit

giving D_1 an impedance of approximately 200 Ω . R_{25} adds D_1 's forward drop through the summing junction of OA_2 such that it appears in the output of OA_2 at a gain of -1. The forward voltage drop of D_1 varies with temperature approximately 2 mV/ $^{\circ}C$. The forward voltage drop of D_2 will vary at the same rate. The compensation thus adds enough drift to OA_2 's output voltage to compensate for the drift of D_2 .

For optimum compensation, D_1 and D_2 should be matched and co-located so they will track in temperature. Note that this scheme will not compensate for all the drift of the circuit. The shape of the "knee" drifts slightly because a diode depends on absolute temperature for its transimpedance. The circuit shown minimizes this effect by matching the currents through D_1 and D_2 at the point of 10 dB compression (for R_{19} at its maximum setting).

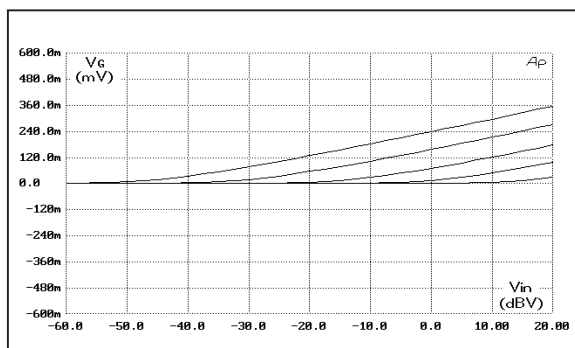

Figure 8. V_G vs. V_{IN} for the Soft-Knee Circuit

The final difference between the circuits of Figure 1 and Figure 6 is in the resistor values around OA_3 . R_{20} was scaled upwards to reduce loading on R_{19} , R_{23} was changed to produce a gain of 0.55 (approximately 1/1.8). This compensates for the control path gain introduced by OA_2 and its associated components, and for the loss caused by D_2 . (The compensation for D_2 is approximate, since the diode's impedance varies with current.) And, R_{22} was scaled to produce a ± 20 dB gain command at V_G . The gain from V_{RMS} to V_G is approximately 1.0 for signals far above threshold (those which turn on D_2), with R_{19} at its maximum rotation.

The THRESHOLD, COMPRESSION, and GAIN controls operate just as they did in Figure 1. THRESHOLD adds in a varying offset to raise or lower the apparent input signal level (from the point of view of the threshold detector); COMPRESSION allows attenuation of the signal above-threshold voltage, and GAIN allows addition of a varying offset to the static gain of the 218X VCA.

The result of these changes is to produce a family of "soft-knee" characteristic curves, as shown in Figure 8, Page 6 and Figure 9, Page 6. Note the similarity in shape between the plots of control voltage versus input voltage and the plot of output voltage versus input voltage. The 2252 and 218X allow the designer to execute a desired compression characteristic by designing a dc-processing circuit which has that transfer characteristic. This makes achieving unusual characteristics particularly easy with these parts.

Closing Thoughts

THAT Corporation welcomes comments, questions and suggestions regarding this application note and its subject matter. Our engineering staff has extensive experience in designing commercial compressor/limiters based on the THAT 2180/2181 Series VCAs and 2252 rms-level detectors. We are pleased to offer assistance in optimizing circuitry for your application. Please feel free to contact us with your thoughts and questions.

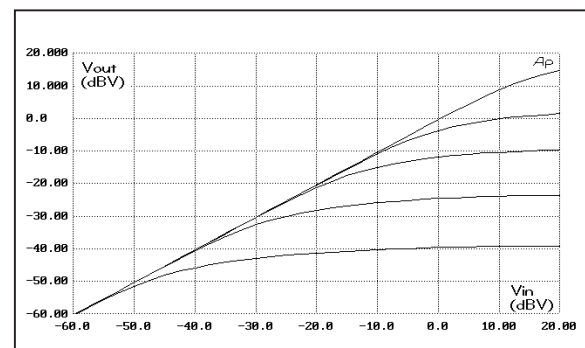

Figure 9. V_{OUT} vs. V_{IN} for the Soft-Knee Circuit