

FEATURES

- Low Noise:
-128.9dBu (1.9nV/√Hz) EIN@60dB gain
- Low THD+N:
0.001% ≤ 40 dB gain
0.006% @ 60 dB gain
- Low Current: 7.0 mA typ
- Wide Bandwidth: 1.7MHz @40dB gain
- High Slew Rate: 50 V/μs
- Wide Output Signal Swing: > +28dBu
- Gain adjustable from 0 to >60 dB
- Differential output
- Small 4 x 4mm QFN16 package
- Mates with THAT's family of Digital Preamplifier Controller ICs

APPLICATIONS

- Microphone Preamplifiers
- Digitally-Controlled Microphone Preamplifiers
- Differential Low-Noise Preamplifiers
- Differential Summing Amplifiers
- Differential Variable-Gain Amplifiers
- Moving-Coil Transducer Amplifiers
- Line Input Stages
- Audio
- Sonar
- Instrumentation

Description

The THAT 1583 is a versatile, high performance current-feedback amplifier suitable for differential microphone preamplifier and bus summing applications. It improves on previous, traditional current-feedback designs (viz. THAT's 1510 & 1512) by offering a more versatile configuration that can yield lower noise at low gains, lower distortion overall, and higher slew rate.

Amplifier gain is determined by three external resistors (R_A , R_B , and R_C). This makes it possible to optimize noise and bandwidth over a wide range of gains, as well as optimize the taper of gain vs. rotation in variable-gain, pot-controlled applications.

The 1583's differential output simplifies connections to differential input devices such as A/D converters. When required, designers are free to

optimize the output differential amplifier to suit the specific application.

In analog variable-gain applications the part supports the traditional approach using fixed R_A and R_B and a single-section variable element for R_C . But, it also supports a dual-element alternative that offers improved performance.

In addition to analog-controlled applications, the 1583 is designed to mate perfectly with THAT's series of Digital Preamplifier Controller ICs to produce an optimized, digitally controlled preamplifier.

The 1583 operates from as little as ± 5 V up through ± 18 V supplies. It accepts greater than +28 dBu input signals at unity gain when operated from ± 18 V supplies.

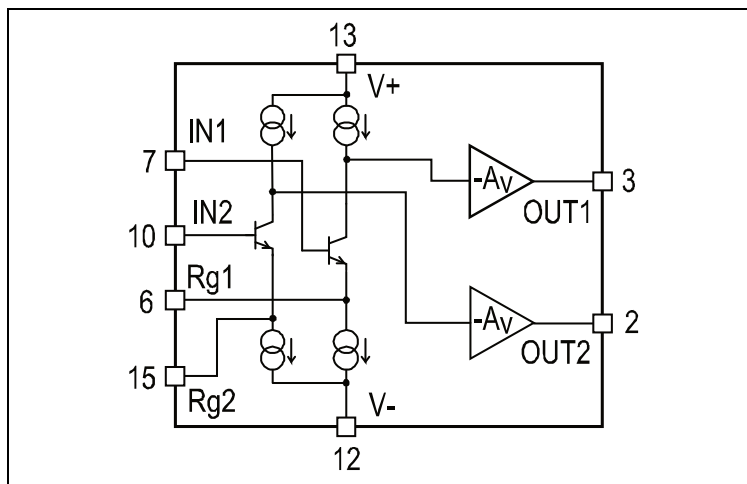

Figure 1. THAT1583 Block Diagram

Pin Name	QFN Pin
N/C*	1
OUT2	2
OUT1	3
N/C*	4
N/C*	5
Rg1	6
IN1	7
N/C*	8
N/C*	9
IN2	10
N/C*	11
V-	12
V+	13
N/C*	14
Rg2	15
N/C*	16
V-	Thermal Pad

Table 1. Pin Assignments

* N/C pins should be left open and not connected to other traces on the PCB

SPECIFICATIONS¹

<u>Absolute Maximum Ratings²</u>			
Supply Voltage (V+) - (V-)	40 V	Operating Temperature Range (T _{OP})	-40 to +85 °C
Maximum Input Voltage (V _{IMAX})	(V+) +0.5V to (V-)-0.5V	Junction Temperature (T _{JMAX})	+125 °C
Storage Temperature Range (T _{STG})	-40 to +125 °C	Output Short-Circuit Duration, between outputs and/or GND (t _{SH})	Continuous

<u>Electrical Characteristics^{3,4,5}</u>						
Parameter	Symbol	Conditions	Min	Typ	Max	Units
Power Supply						
Supply Voltage	V+; - (V-)	Referenced to GND	5	—	18	V
Supply Current	I+; -(I-)	No Signal	—	7.0	10	mA
Input Characteristics						
Input Bias Current	I _B	No signal; either input connected to GND	—	2.0	4.4	μA
Input Offset Current	I _{B-OFF}	No signal	-440	—	+440	nA
R _G Input Bias Current	I _{BRG}	No signal	-20	+2	+20	μA
R _G Input Offset Current	I _{BRG-OFF}	No signal	-4.5	—	+4.5	μA
Differential Input Offset Voltage	V _{OS}	No signal, Includes I _{BRG-OFF} * R _G 0 dB gain +60 dB gain	-15 -450	— —	+15 +450	mV μV
Input Common Mode Voltage Range	V _{IN-CM}	Common Mode	(V-) + 1.5	—	(V+) -4	V
Maximum Differential Input Level	V _{IN-BAL}	R _G = ∞ Supply Voltage ±18V	— —	26.4 28.0	— —	dBu dBu
Output Characteristics						
Differential Output Offset		G = gain	-(15 + 0.45*G)	—	(15 + 0.45*G)	mV
Common Mode Output Voltage	V _{OscM}	No signal; IN1, IN2 connected to GND	—	-630	—	mV
Maximum Single Output Voltage	V _{OUT-SINGLE}	G=20dB, R _L = 2 kΩ	(V-) + 1.2	—	(V+) - 2	V
Differential Short Circuit Current	I _{SC}	R _L = 0 Ω	—	± 70	—	mA
Maximum Capacitive Load	C _{L MAX}	Over entire temperature range Stable operation 30% overshoot	— —	— 75	30 —	pF pF
Maximum Differential Output Level	V _{OUT}	R _L = 2 kΩ Gain > 2 dB	28	—	—	dBu

1. All specifications are subject to change without notice.

2. Stresses above those listed under "Absolute Maximum Ratings" may cause permanent damage to the device. These are stress ratings only; the functional operation of the device at these or any other conditions above those indicated in the operational sections of this specification is not implied. Exposure to absolute maximum rating conditions for extended periods may affect device reliability.

3. Unless otherwise noted, T_A = 25°C, V+ = +15V, V- = -15V.

4. 0 dBu = 0.775 Vrms

5. Unless otherwise noted, feedback resistors = 2.21 kΩ; C_L = 10 pF. Circuit is as shown in Figure 15.

Electrical Characteristics (con't) ^{3,4,5}							
Parameter	Symbol	Conditions	Min.	Typ.	Max	Units	
AC Characteristics							
Feedback Impedance	$R_A = R_B$	Refer to Figure 15	2	—	—	k Ω	
Differential Gain	A_V	Programmed by R_A, R_B, R_G Refer to Figure 15	0	—	70	dB	
Power Supply Rejection Ratio	PSRR	$V_+ = -(V_-); \pm 5V$ to $\pm 18V$	—	105	—	dB	
		0 dB gain	—	116	—	dB	
		20 dB gain	—	140	—	dB	
		40 dB gain	—	140	—	dB	
Bandwidth -3dB	f_{-3dB}	Small signal; $R_A=R_B=2.21k\Omega$; Refer to Figure 5	—	14	—	MHz	
		0 dB gain	—	9	—	MHz	
		20 dB gain	—	1.7	—	MHz	
		40 dB gain	—	192	—	kHz	
		60 dB gain	Small signal; $R_G=\infty$ (0 dB gain)	—	16	—	MHz
		$R_A = R_B = 2 k\Omega$	—	4	—	MHz	
		$R_A = R_B = 10 k\Omega$	—	1.6	—	MHz	
Slew Rate	SR	$V_{OUT} = 10V_{P-P}; R_L=2k\Omega$ $C_L=30pF; G=20dB$	—	50	—	V/ μ s	
Total Harmonic Distortion + Noise	THD + N	$V_{OUT} = 5V_{RMS}; R_L=2k\Omega; f=1kHz; BW=22kHz$	—	0.0006	—	%	
		0 dB gain	—	0.0008	—	%	
		20 dB gain	—	0.001	—	%	
		40 dB gain	—	0.006	—	%	
Equivalent Input Noise Voltage	e_N	Inputs connected to GND; $f=1kHz$ $R_A = R_B = 2.21k\Omega$; Refer to Figure 15	—	40	—	nV/ \sqrt{Hz}	
		0 dB gain	—	5.7	—	nV/ \sqrt{Hz}	
		20 dB gain	—	2.3	—	nV/ \sqrt{Hz}	
		40 dB gain	—	1.9	—	nV/ \sqrt{Hz}	
		60 dB gain	BW = 22kHz	—	-128.9	—	dBu
		60 dB gain	A - weighted ; BW = 22kHz	—	-131.2	—	dBu
		60 dB gain	Inputs connected to 150 Ω ; BW = 22kHz	—	-126.5	—	dBu
		60 dB gain	Inputs connected to 150 Ω ; A - weighted	—	-129.3	—	dBu
Equivalent Input Noise Current	i_N	$f = 1kHz; 60 dB gain$	—	0.8	—	pA/ \sqrt{Hz}	
Noise Figure	NF	60 dB gain; Source impedance = 150 Ω	—	3.9	—	dB	

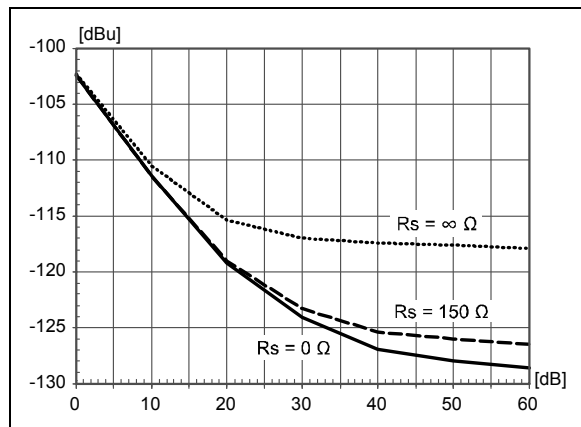

Figure 2. Equivalent Input Noise vs Gain and Source Impedance; BW: 22Hz to 22kHz

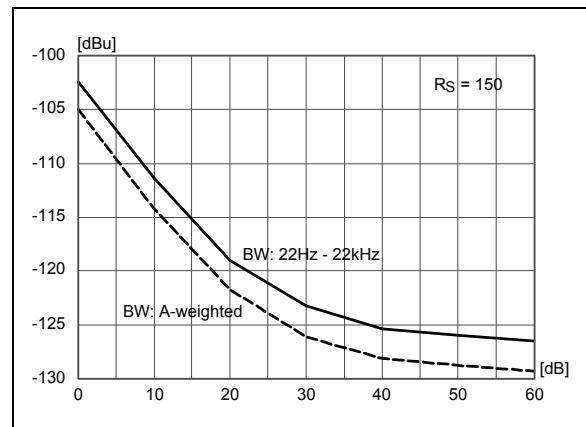

Figure 3. Equivalent Input Noise vs Gain and Bandwidth, Source Impedance 150 Ω

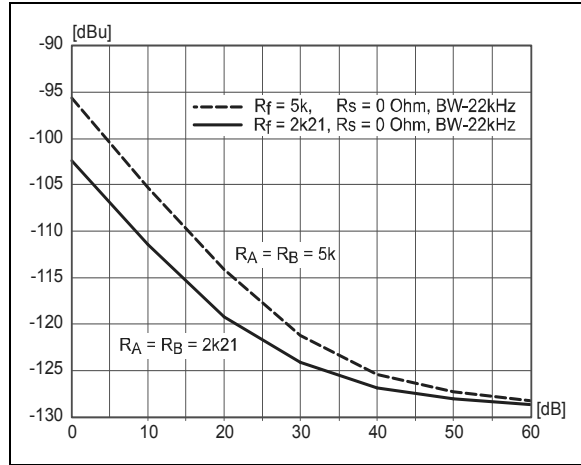

Figure 4. Equivalent Input Noise vs Gain and Feedback Impedance; BW: 22Hz to 22kHz

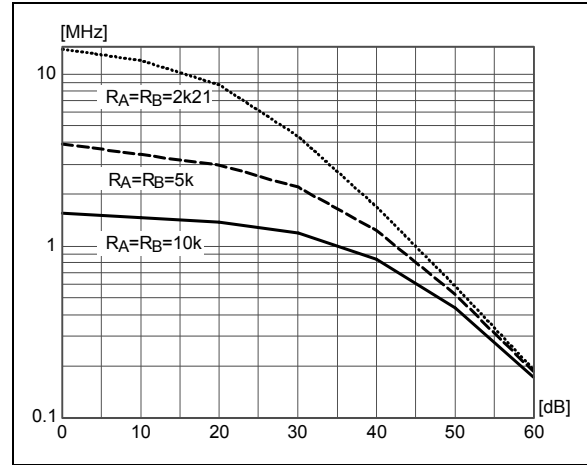

Figure 5. Bandwidth vs Gain and Feedback Impedance

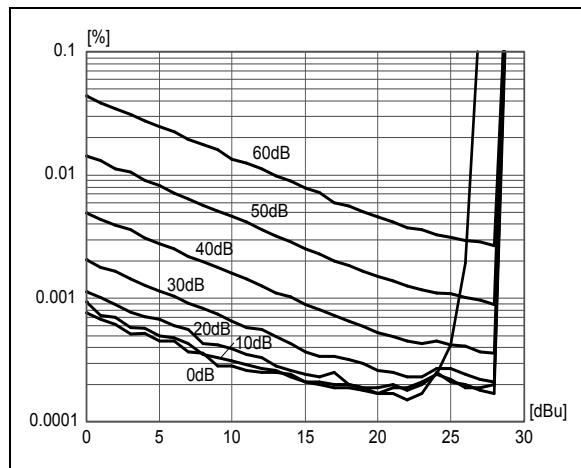

Figure 6. THD + Noise vs Level

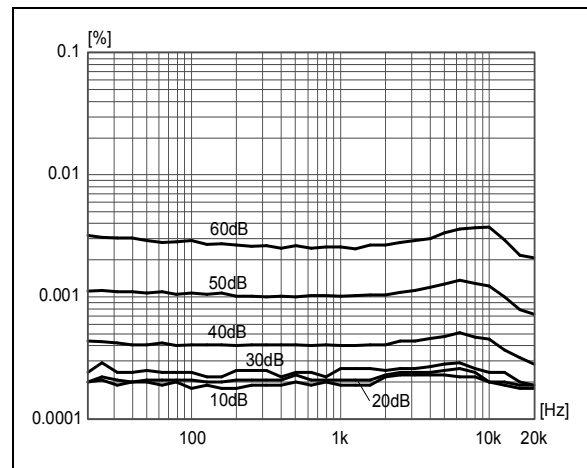

Figure 7. THD + Noise vs Frequency; $V_{out} = 27\text{dBu}$, $R_L = 10\text{k}\Omega$

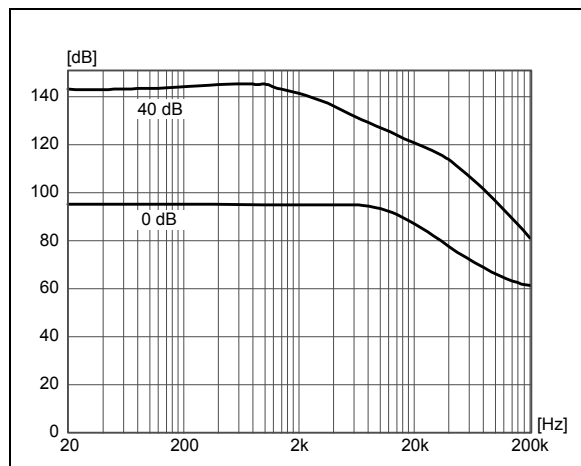

Figure 8. Power Supply Rejection vs Frequency

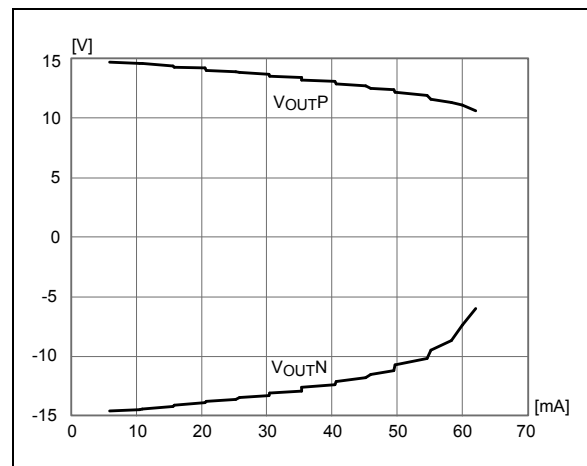

Figure 9. Maximum Output Voltage vs Output Current

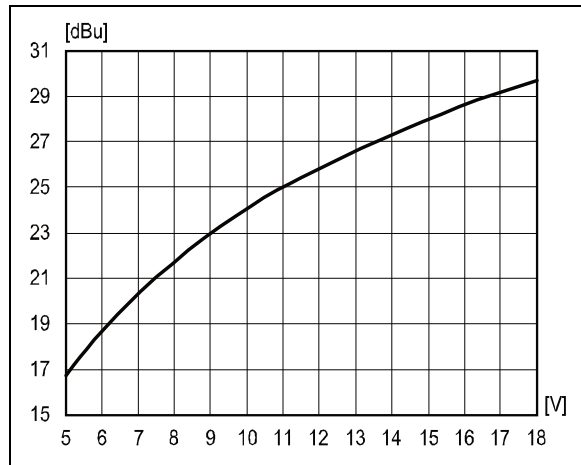

Figure 10. Maximum Output Level vs. Supply Voltage

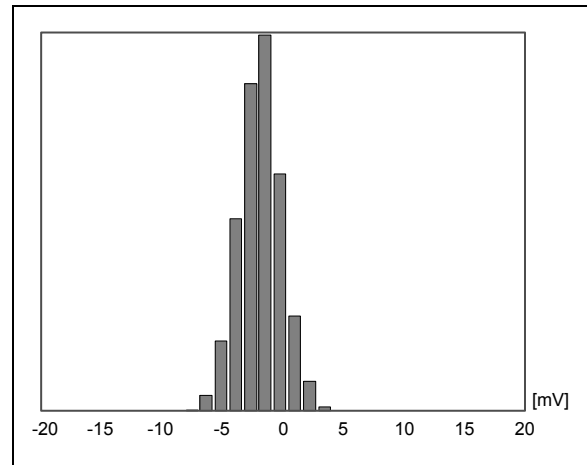

Figure 11. Representative Output Offset Voltage Distribution, 0dB Gain

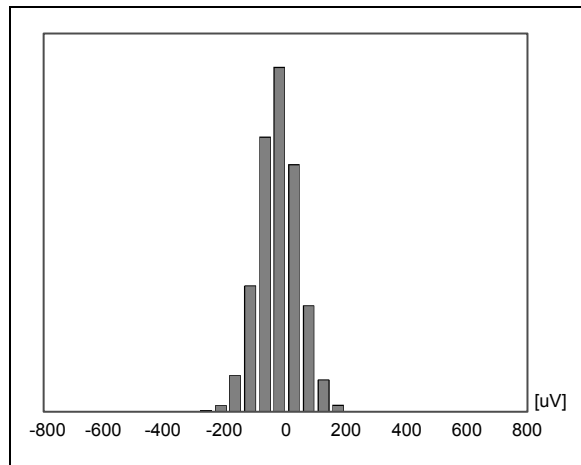

Figure 12. Representative Input Offset Voltage Distribution, 60dB Gain

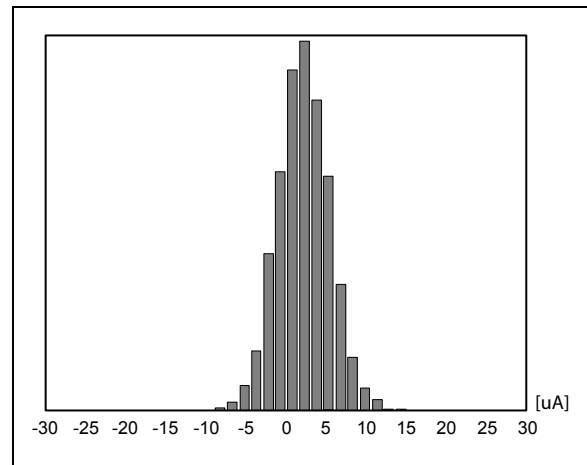

Figure 13. Representative R_G Input Bias Current Distribution

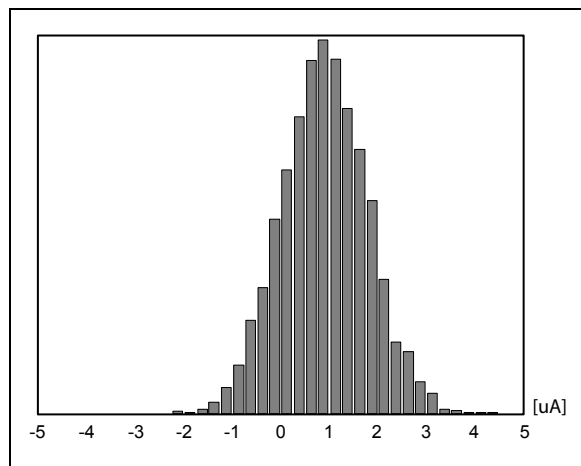

Figure 14. Representative R_G Input Offset Current Distribution

Theory of Operation

Amplifier Overview

Referring to Figure 15, the THAT1583's differential voltage gain (G) is set by the feedback resistors (R_A and R_B) and R_G , as shown in the following equation. The amplifier's minimum gain is unity (0 dB), which occurs with infinite R_G . The feedback resistors should nominally be equal, though tight tolerance matching is not required.

$$G = 1 + \frac{R_A + R_B}{R_G}$$

In low-noise current-feedback amplifiers like the 1583, many performance characteristics depend critically on the impedance of the feedback network (R_A , R_B , and R_G).

The 1583 (and 1570) offers a novel approach to an integrated microphone preamplifier in that all three gain resistors are external. This gives the designer freedom to select the optimal values for the best noise performance at the desired gain setting(s).

Noise versus Gain

The noise performance of a preamplifier based on the 1583 is determined as the sum of several noise sources. These are as follows (refer to Figure 15 for component reference designators):

1. the amplifier's own input voltage noise;
2. the voltage noise of the gain-setting resistor network (R_G in parallel with R_A and R_B);
3. the voltage noise of the external source impedance, connected to the 1583's input (R_M in parallel with $R_1 + R_2$);
4. the current noise from IN+ and IN-, developed across the source impedance (R_M in parallel with $R_1 + R_2$), and
5. the current noise from R_{G1} and R_{G2} , translated to a voltage when drawn across the equivalent impedance of the external gain-setting resistor network (R_G in parallel with R_A and R_B).

Since all these sources are uncorrelated, mostly random (Gaussian) noise, these sources all add in root-mean-square fashion. But which one is most important changes with gain, so predicting how noise varies can be complex.

A complete discussion of these sources and their interaction is beyond the scope of this data sheet. For more information, see "De-Integrating Integrated Circuit Preamps", available from THAT Corporation's web site, especially pages 13 through 20. However, the following discussion covers the highlights.

At high gains (above 40 dB or so), the system noise is typically dominated by the first three factors in the above list. At high gains, for practical values of R_A , R_B , and R_G (where R_G is typically less 100 Ω) and typical external source impedances (microphones are generally around 150 Ω), the amplifier's input voltage

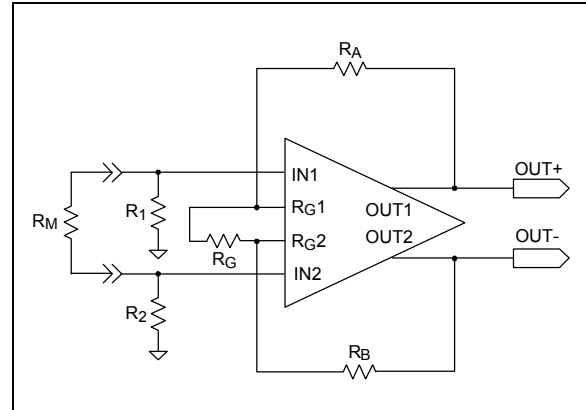

Figure 15. Simple THAT1583 Amplifier Circuit

noise will be the largest contributor. However, at 1.9 nV/ $\sqrt{\text{Hz}}$ (-128.9 dBu unweighted, 22 kHz bandwidth) the amplifier's own input noise is only 1.5 dB higher than that of a 150 Ω microphone (-130.4 dBu). So, the external source impedance R_M is a significant contributor to the total noise of the system.

At low gains (under about 20 dB), the dominant noise sources are factors 2 and 5. An important case occurs at 0 dB (unity) differential gain. In order to reach 0 dB gain, R_G is open (infinite resistance). In this case, the current noise in R_{G1} and R_{G2} is drawn across the highest possible impedance (R_A and R_B alone, without any shunting effect of R_G). The only way to mitigate this noise is to use lower values for R_A and R_B .

Of course, there is a continuum of relative importances here as gain goes from minimum (0 dB) to maximum (over 70 dB). As gain varies, the importance of each factor will vary in its own way, each contributing a different relative amount to the total. In general, to minimize low-gain noise, we suggest to keep R_A and R_B as small as possible.

Another perspective on noise performance is gained by measuring the noise using an A-weighting filter. Figure 3 compares equivalent input noise for various gains in a 22 kHz bandwidth vs. using an A-weighting filter. The A-weighting filter improves input noise performance by about 3 dB.

Bandwidth

An important characteristic of current-feedback amplifiers is that the amplifier bandwidth is inversely proportional to the feedback resistance R_A and R_B . The bandwidth decreases with increasing feedback resistance. As mentioned before, the minimum value of R_A and R_B is determined by the amplifier's stability and cannot be under any condition lower than 2 k Ω . Figure 5 shows typical bandwidth versus gain for a few selected values of feedback resistance.

Note that the widest bandwidth may not always be the optimum condition. In digitally controlled applications using CMOS switches to vary gain, high bandwidth may allow charge injected by the switches to be amplified and sharp voltage spikes to appear at the output. Lower bandwidth can reduce this effect.

Common Mode Gain

The amplifier common-mode gain is always unity (0 dB), regardless of the differential gain. So, any common-mode input signal, along with the amplifier's own common-mode dc offset, will be transferred faithfully without gain or attenuation to the output. The common-mode rejection ratio (CMRR) of the part will equal the differential gain, since differential signals are amplified while common-mode signals are not.

The largest impact of significant common-mode signals is to limit 1583's dynamic range, since they can cause premature clipping of the input and outputs. The same will be true for subsequent stages.

The 1583 output has a typical dc common mode offset of about -600 mV. This constrains output headroom on negative signal peaks by 600 mV. At high power supplies, the 600 mV reduction of output swing may not matter. However, it has a more significant effect at the minimum power supply. If desired, a common-mode servo amplifier can be added to drive the outputs' common-mode voltage to 0 V by lifting the inputs' bias to approximately +600 mV. Note that it is more important to adjust the output to zero bias than the input, because the 1583's input voltage range is typically less than that for its output.

Limiting Differential dc Gain

In the circuit of Figure 15, the amplifier's differential gain (G) extends to dc. As a result, the differential dc offset at the outputs will vary with gain. This can produce audible "thumps" when gain is varied quickly, and can produce significant and undesirable output dc offset at maximum gain. Any such offset will reduce the output voltage swing.

To see how important this is, suppose a particular 1583 has an input offset of 400 μ V and an output offset of 10 mV. The output offset of that part would be 10.4 mV at unity (0 dB) gain. But, at 60 dB gain, the output dc offset will be 410 mV. If the gain is varied quickly, this ~400 mV dc shift will be audible.

This issue can be addressed by ac coupling R_G as shown in Figure 16 with capacitor C_G . The capacitor forces dc gain to unity regardless of the amplifier differential gain. This means the output's differential dc offset will not vary with gain. In the example above, adding C_G will set the output dc offset at 10.4 mV regardless of the differential gain.

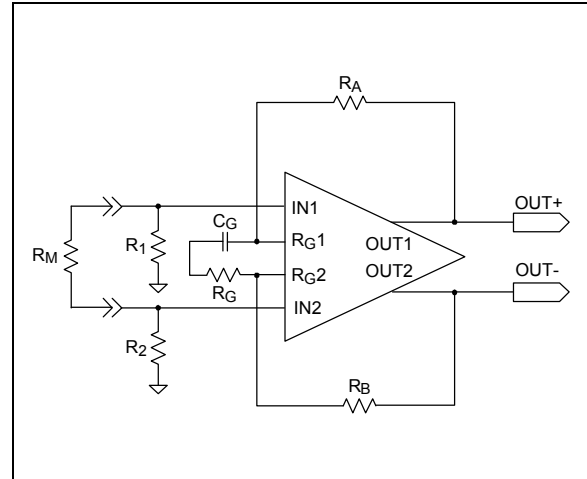

Figure 16. Simple THAT1583 Circuit with C_G

Note that the R_G - C_G network forms a high-pass filter. The high-pass filter's -3 dB corner frequency is determined by the following equation.

$$F_C = \frac{1}{2\pi R_G C_G}$$

Note that the cutoff varies with R_G and therefore with gain. It is highest with lowest R_G (which occurs at the highest gain). This can be a desirable effect in that at high gains it can significantly reduce the low frequency rumble and noise from wind or microphone handling.

Consider the circuits shown in Figure 17, which has a fixed and variable R_G (R_{GF} and R_{GV}). At maximum gain (60 dB), $R_G = 10 \Omega$. With $C_G = 3,300 \mu$ F, the high-pass corner frequency is approximately 5 Hz. But, at minimum gain (6 dB), $R_G = 10k\Omega$. This drives the cutoff down to 0.005 Hz. It may well be acceptable to reduce C_G by a factor of 10, to 330 μ F. In this case the high-pass corner would vary from 50 Hz at 60 dB gain to 0.05 Hz at 6 dB gain.

The dc voltage appearing across C_G is very small, less than 450 mV, though its polarity will vary from sample to sample. C_G is usually a low voltage electrolytic type; 6.3 V is generally sufficient. Since polarized electrolytic capacitors normally can withstand some small reverse bias, C_G can be a polarized capacitor

Applications

Analog Gain Control

Traditional integrated microphone preamplifiers include the feedback resistors (e.g., the THAT1510 and THAT1512) and allow gain to be varied using an external single-element potentiometer. The 1583 supports a similar configuration in that the designer may select fixed feedback resistors (R_A and R_B), and vary R_G as shown in Figure 17. This circuit provides a maximum gain of 60 dB (when $R_G = 10\Omega$ because $R_{GV} = 0\Omega$) and a minimum gain of 6 dB (when $R_G = 10,010\Omega$ because $R_{GV} = 10\text{ k}\Omega$).

Refer to Figure 4 for typical noise versus gain with 5 k Ω feedback resistors (R_A and R_B). Other minimum and maximum gains, and noise versus gain performance, can be accommodated by selecting different values of R_A , R_B , R_{GV} and R_{GF} . Typically, reverse log (audio) taper elements offer the desired behavior in gain versus rotation wherein gain increases with clockwise rotation.

An interesting and novel technique permitted by the 1583's "deconstructed" topology is to vary all three resistors simultaneously, as shown in Figure 18. Here, we use a dual-element potentiometer as the gain control. High gain occurs by decreasing R_G while simultaneously increasing the feedback resistances. There are a few advantages of this approach. First, the feedback resistances (and their associated noise contribution) will be reduced at low gains. Second, the value of R_G required to achieve high gains is higher. The larger resistance of R_G at maximum gain allows a smaller C_G for a given cutoff at maximum gain than with a single-element control. This may

also relax requirements for end resistance in the pot used. Third, the dual-element approach can improve the linearity of gain vs. pot rotation compared to a single-element solution, assuming the same taper in the pot. Fourth, the dual-element approach lends itself to a lower low-gain limit.

The circuit in Figure 17 has a gain range of 6 dB to 60 dB while the circuit shown in Figure 18 provides a gain range of 4.4 dB to 60 dB. The noise behavior of the two circuits is compared in Figure 19. Note the superior low-gain noise performance with the dual-element approach.

Again, other minimum and maximum gains and noise versus gain performance can be accommodated by selecting different values of gain resistances.

Potentiometer Limitations and Gain Accuracy

Overall gain accuracy depends on the tolerance of the external gain resistors and especially the potentiometer. Theoretically, when the variable portion of R_G is zero for maximum gain, the gain is determined by the feedback resistors and fixed portion of R_G . However, in many instances the minimum resistance of the potentiometer (commonly specified as end resistance) will be greater than zero and can vary from part to part. Reducing the fixed portion of R_G by the amount of the end resistance may be appropriate if the potentiometer end-resistance is consistent. It may be easier to maintain

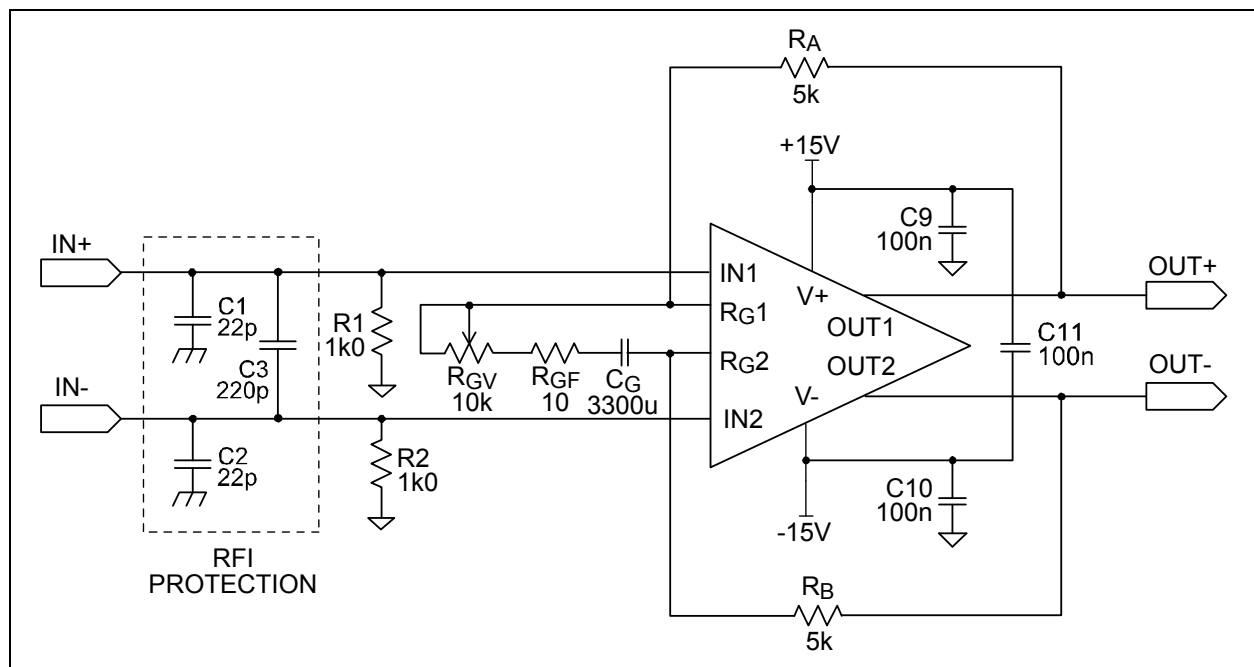

Figure 17. Basic Application Circuit With Variable R_G for Gain Control, ac-Coupled R_G

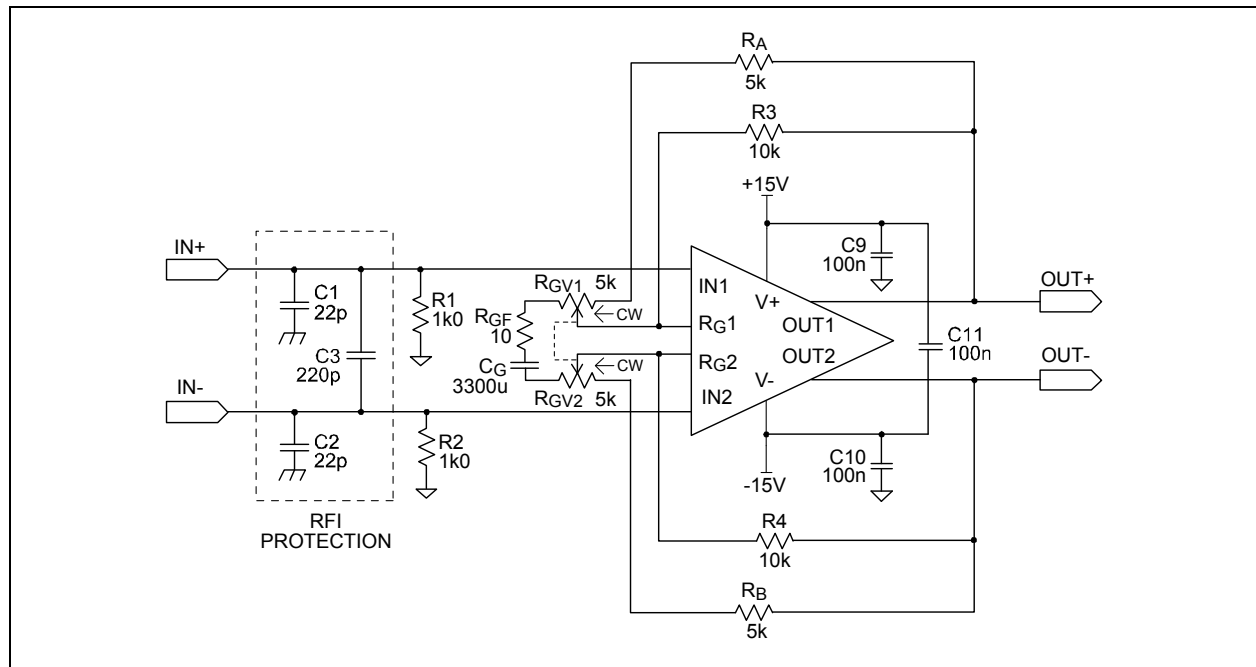

Figure 18. Basic Application Circuit With Variable Feedback Resistors and R_G for Gain Control, ac-Coupled R_G

consistency at high gains with larger values of feedback resistances, since this makes the required value of R_G proportionately larger for any given gain, and minimizes the effects of end resistance. For high-accuracy applications, consider discrete, switched resistors for R_A , R_B and R_G .

As well, take care to specify the potentiometer's element construction to avoid excess noise.

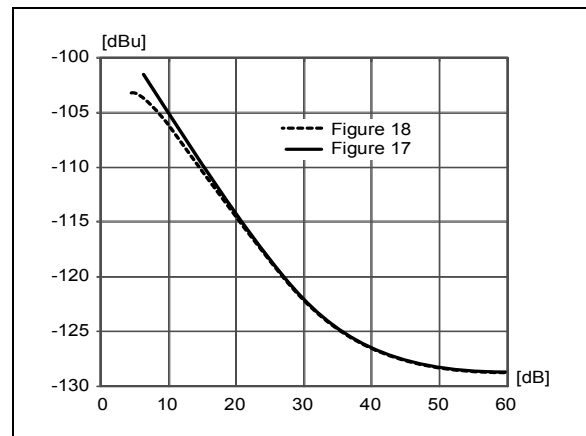

Figure 19. Noise vs Gain of circuits in Figures 17 and 18

Digitally Controlled Gain

In addition to analog-controlled applications, the 1583 has been designed to mate perfectly with THAT's family of Digital Preamplifier Controller ICs to produce an optimized, digitally controlled audio preamplifier. THAT's digital controllers are intended primarily for use in the feedback loop of differential, current-feedback gain stages, such as the 1583.

Figure 20 shows a THAT5171 or 5173 Digital Controller connected to the 1583. The controller varies R_A , R_B and R_G (from Figure 15) to produce the desired gain based on the gain command provided via the SPI control interface. The feedback network

impedances in these controller ICs have been chosen to minimize noise and distortion within the combined amplifier and controller at each gain step.

The controllers also include a differential servo amplifier which minimizes the differential dc offset at the output. The servo generates a correction voltage at the 1583 inputs which in turn reduces the output offset voltage. The output dc offset is controlled by the servo amplifier inside the controller, making CG unnecessary, and enabling a more compact PCB design.

Please refer to the 5171 and 5173 data sheets for more information.

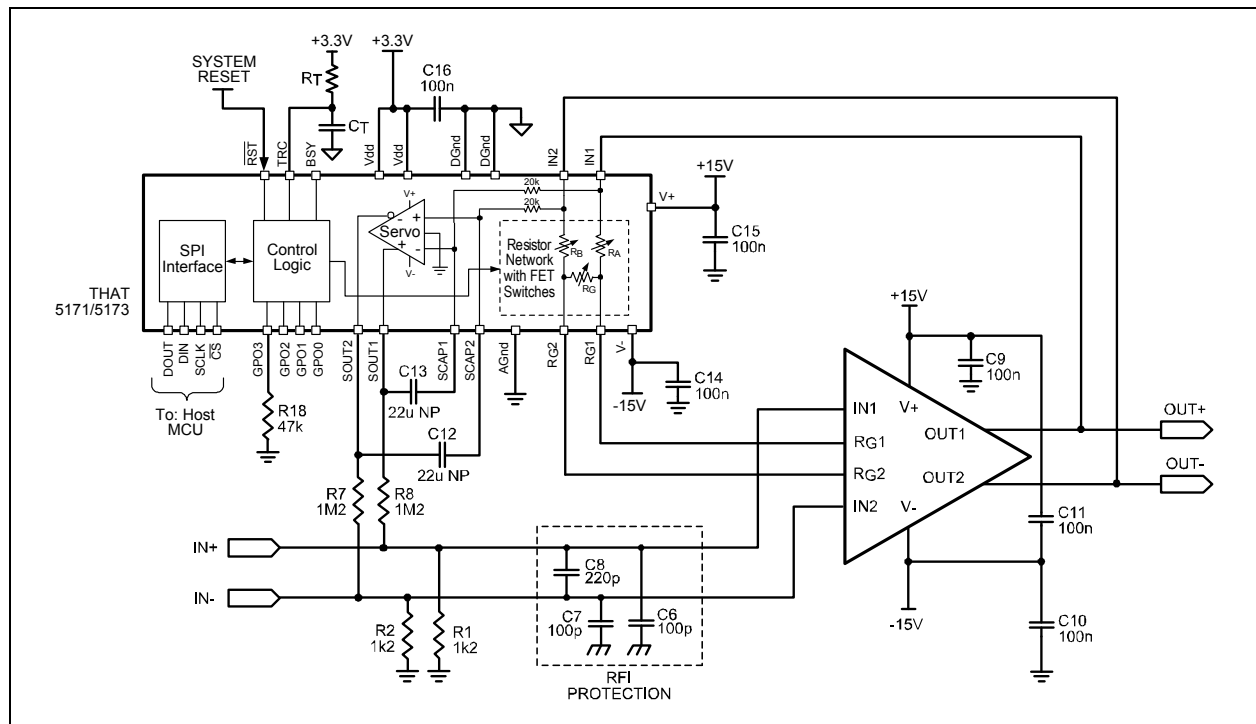

Figure 20. Basic Application Circuit with THAT 5171/5173 Digital Controller

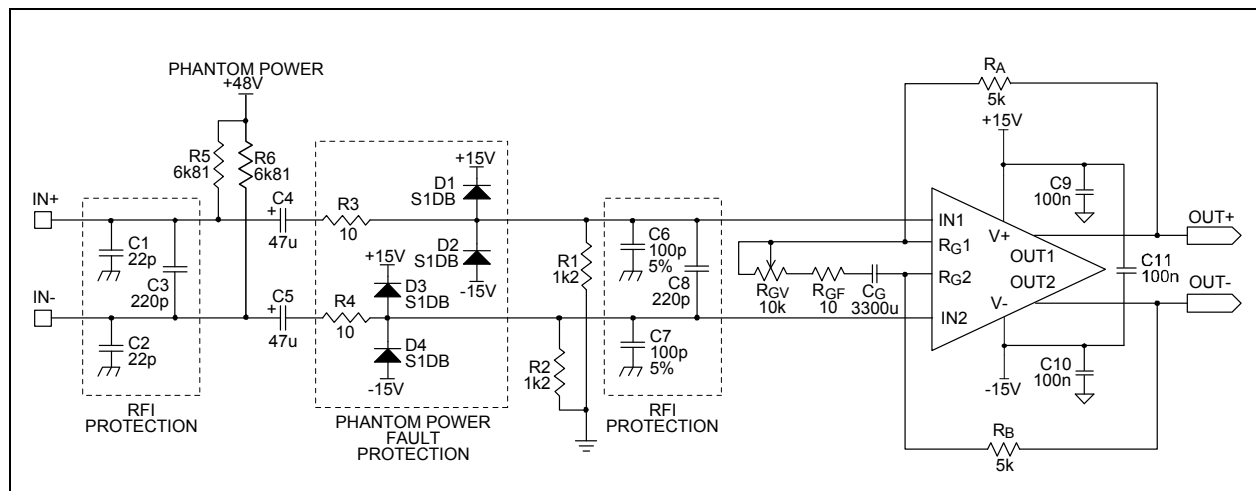

Figure 21. Typical Phantom Power Application Circuit with Variable R_G for Gain Control, ac-Coupled R_G

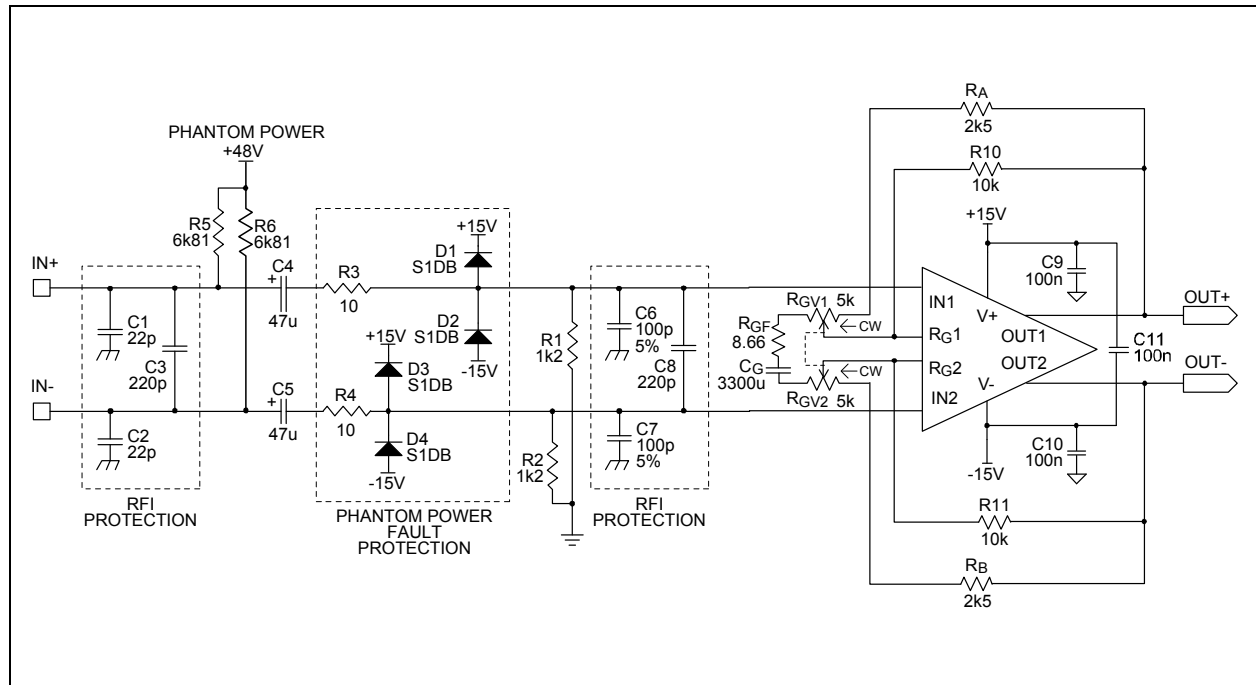

Figure 22. Typical Phantom Power Application Circuit With Variable R_A , R_B and R_G for Gain Control, ac-Coupled R_G

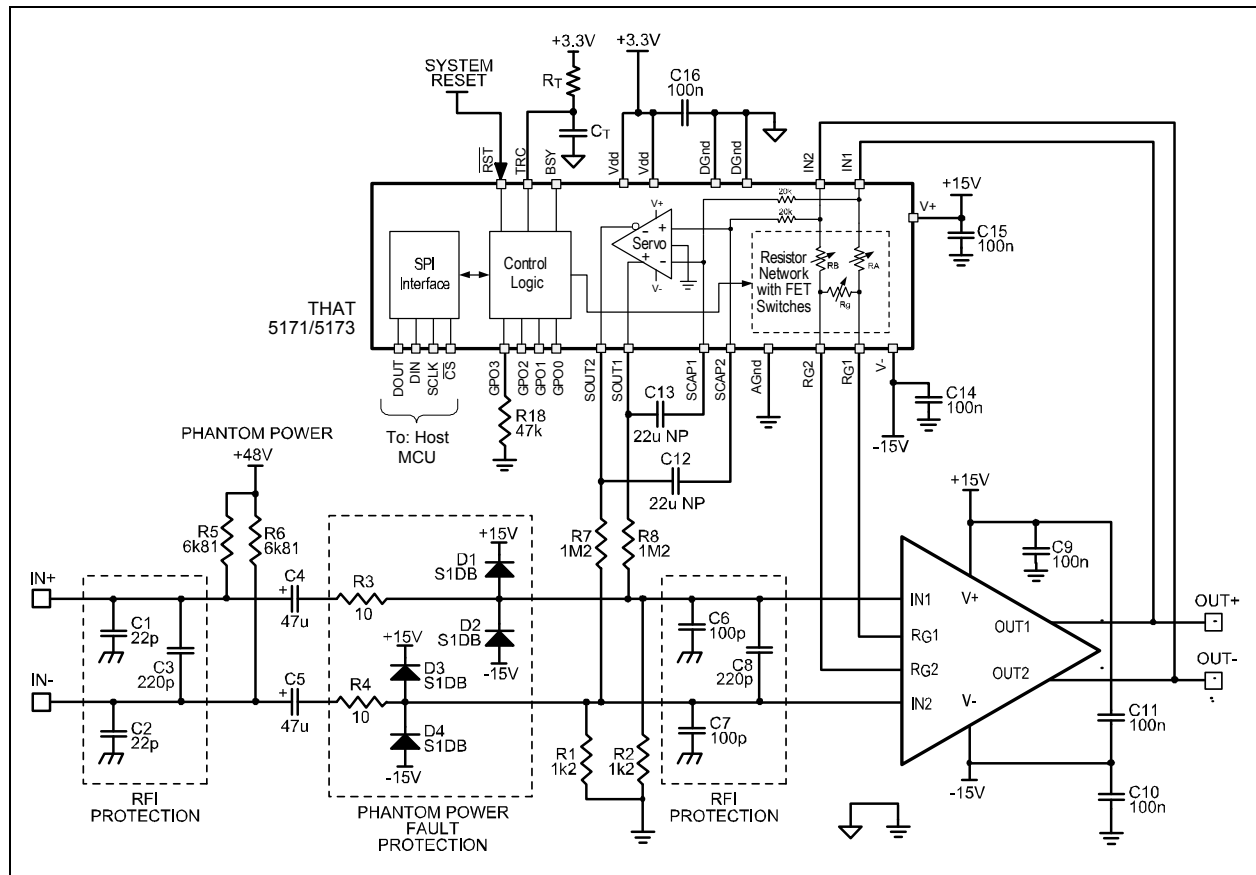

Figure 23. Typical Phantom Power Application Circuit With Digital Gain Control

Output Circuit Recommendations

As mentioned earlier, the THAT1583 has common-mode gain of unity, regardless of its differential gain. It also has a common-mode offset of approximately one diode drop. Common-mode input signals are presented at the output, along with the common-mode dc offset. If these common-mode signals are not removed, they may limit dynamic range of subsequent stages.

If a single-ended output is desired, the THAT1246 offers a convenient way to remove common mode offset, convert to single-ended, and match the headroom of the 1583's output to a single-ended drive. See Figure 24.

See DN140 which contains much additional information and many alternative recommended solutions.

Additional Resources

THAT's engineers have spent years investigating and documenting circuit topology options, component selection and reliability issues related to microphone preamplifiers. We recommend the following design notes and technical papers, which offer additional insights into microphone preamp design.

1. THAT Design Note 140 (DN140) "Input and Output Circuits for THAT Preamplifier ICs"
2. "The 48 Volt Phantom Menace," by Gary K. Hebert and Frank W. Thomas, presented at the 110th Audio Engineering Society (AES) Convention
3. "The Phantom Menace Returns" by Rosalfonso Bortoni and Wayne Kirkwood, presented at the 127th AES Convention.

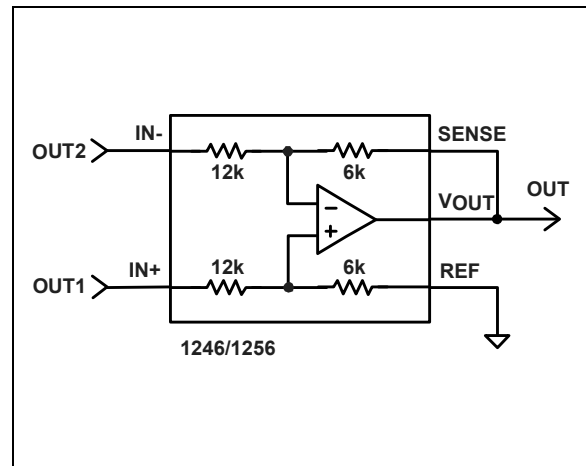

Figure 24. Simple single-ended output

4. "De-Integrating Integrated Circuit Preamps" by Les Tyler, presented at the 131st AES Convention.

DN140 is of particular interest in that this design note was intended to cover the diverse and multifaceted topic of integrating an amplifier/controller combination into a fully functioning microphone preamplifier. DN140 was written before the 1583 was released. All the circuits in DN140 reference the THAT 1570 differential preamplifier, but all the circuits and notes can be applied to the 1583 as well. The circuits presented in DN140 address common applications requirements, performance enhancements, component selection, and fault protection. DN140 should be considered an addendum to this data sheet.

PCB Layout Information

The QFN package includes a metal thermal pad which should be soldered to the PCB. Five thermal vias should be arranged in the configuration shown in Figure 25 to provide uniform heat distribution between the top layer of the PCB to the bottom layer. The thermal pad can be left electrically floating. However if it is not electrically floating, it should be connected only to V-.

For current feedback amplifiers, stray capacitance from the R_G pins (inverting inputs) to ground or power planes result in higher gains at high frequencies. This compromises common-mode rejection at high frequencies and, in extreme cases, can even lead to oscillation. Take care to avoid ground and power planes under and near R_A , R_B , R_G , their associated pins and traces.

The input signal lines are susceptible to magnetic pickup from power supply currents, which often take the form of half-wave rectified versions of the signal. Voltage fluctuations on the supply lines can couple capacitively as well. For this reason, take care not to run power and input signal lines close and/or parallel to each other

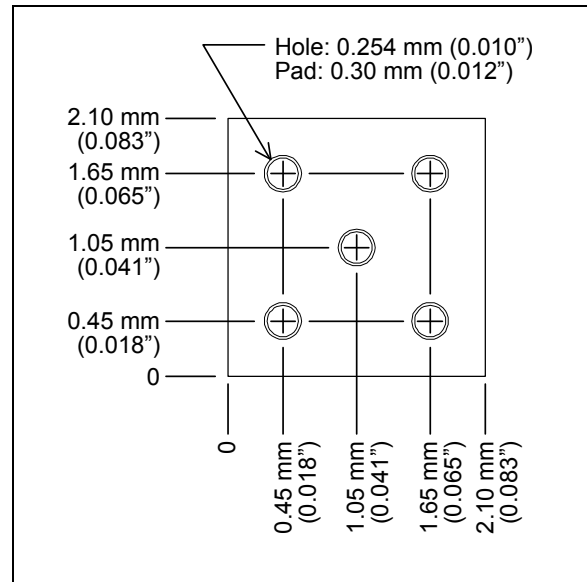

Figure 25. QFN-16 Thermal Solder Pad

Package and Soldering Information

<u>Package Characteristics</u>				
Parameter	Symbol	Conditions	Typ	Units
Package Style		See Fig. 26 for dimensions	16 Pin QFN	
Thermal Resistance	θ_{JA}	QFN package soldered to board ⁸	110	°C/W
Environmental Regulation Compliance		Complies with July 21, 2011 RoHS 2 requirements		
Soldering Reflow Profile		JEDEC JESD22-A113-D (250 °C)		
Moisture Sensitivity Level	MSL	Above-referenced JEDEC soldering profile	3	

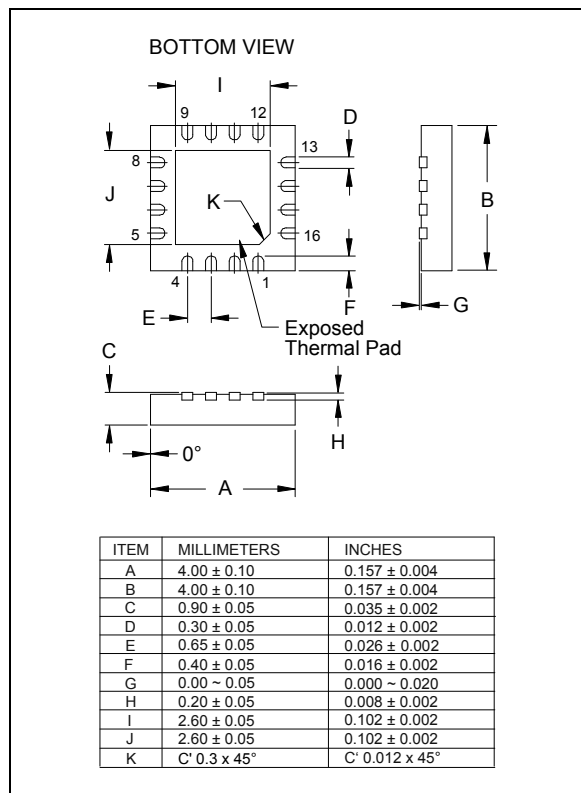

Figure 26. QFN-16 Surface Mount Package

Package	Order Number
16 pin QFN	1583N16-U

Table 2. Ordering Information

<u>Revision History</u>				
Revision	ECO	Date	Changes	Page
00	—	10/24/12	Initial Release	—
01	2827	10/01/13	Added footnote to pin assignment chart.	14
02	2912	01/26/15	Corrected the moisture sensitivity level specification.	14
03	2980	07/20/16	Change Differential Input Offset Voltage spec. Add RG Input Bias Current and RG Input Offset Current specs.	—

Notes