

FEATURES

- Basic Compressor/Limiter Circuit
- Threshold
- Compression Ratio
- Output Gain
- Preassembled and Pretested
- Socket for THAT4301P/PA
- XLR Input/Output Connectors
- Generous Prototyping Area
- Complete Documentation Package
- Schematic and Assembly Drawing

APPLICATIONS

- Verification of 4301 Performance
- Compressor/Limiter Application Evaluation
- Prototyping 4301 Applications
- PCB Layout Reference Design

Description

The THAT4301 Demonstration System is a self-contained circuit board that simplifies evaluating the performance of a 4301 Analog Engine® Dynamics Processor IC. It features the 4301 connected in a basic three-control (ratio, threshold and gain) compressor/limiter circuit. An external (± 15) power supply is required.

Completely assembled and tested, the THAT4301 Demonstration System comes with XLR connectors for signal input and output. A socket is provided for inserting a THAT 4301P or 4301PA. Power supply connections are

made via a 3-pin 0.1-inch-center Molex connector.

To facilitate prototyping specific applications, spare circuit board area is perforated with plated-through holes. This makes the board particularly useful for experimentation.

With a 4301 Demonstration System and standard audio cables, an engineer can start testing the performance of basic 4301 circuitry and begin trying out additional circuit ideas in minutes.

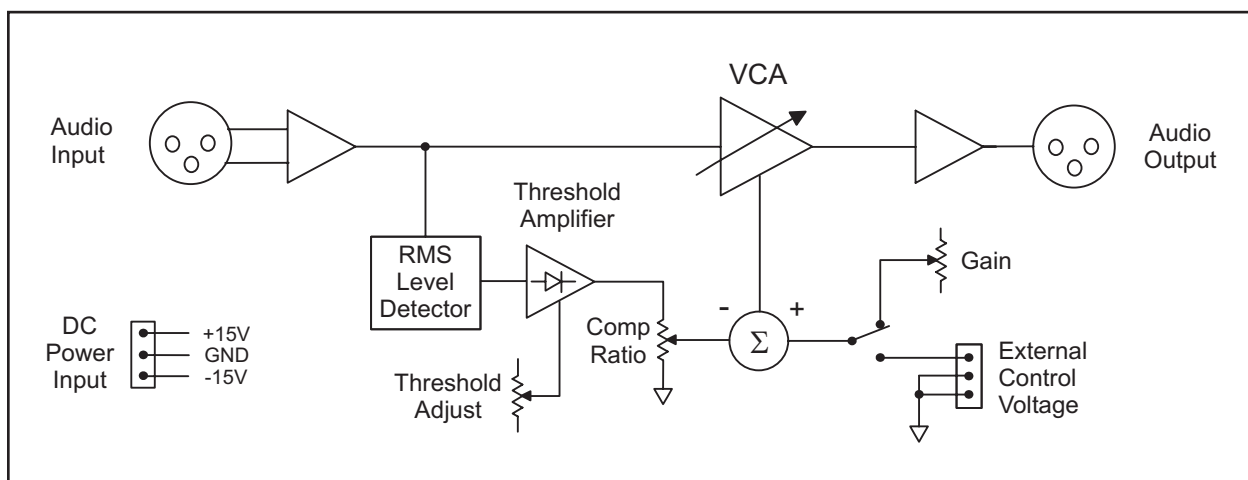

Figure 1. 4301-DEMO Block Diagram

SPECIFICATIONS¹**Absolute-Maximum Ratings ($T_A = 25^\circ\text{C}$)**

Positive Supply Voltage (V_{CC})	+18 V	Operating Temperature Range (T_{OP})	0 to +70°C
Negative Supply Voltage (V_{EE})	-18 V	Storage Temperature Range (T_{ST})	0 to +100°C

Typical Power Supply Requirements

Parameter	Symbol	Conditions	Min	Typ	Max	Units
Positive Supply Voltage	V_{CC}		+8	+12	+15	V
Negative Supply Voltage	V_{EE}		-8	-12	-15	V

Electrical Characteristics²

Parameter	Symbol	Conditions	Min	Typ	Max	Units
Gain Range		Internal Control	-20	—	+20	dB
		External Control	-90	—	+30	dB
Control Voltage Constant		External Control	88	100	112	mV/dB
Supply Current	I_S	± 15 V Supply	—	28	40	mA
Input Impedance, Audio	Z_{IN}	Differential	19.6	20	20.4	k Ω
Input Impedance, Control	Z_{IN}	Differential	—	80	—	k Ω
Input Overload	$V_{IN (Max)}$	$V_{CC} = -V_{EE} = 15$ V	+18	+19	—	dBV
Output Impedance	Z_{OUT}	Single-ended	95	100	105	Ω
Minimum Resistive Load	$R_{L MIN}$		600	—	—	Ω
Maximum Capacitive Load	$C_{L MAX}$		—	—	1	nF
Dimensions				5 x 7 x 1.5		in
Weight				0.4		lb

1. All specifications subject to change without notice
2. Unless otherwise noted, $T_A = 25^\circ\text{C}$, $V_{CC} = +15\text{V}$, $V_{EE} = -15\text{V}$.

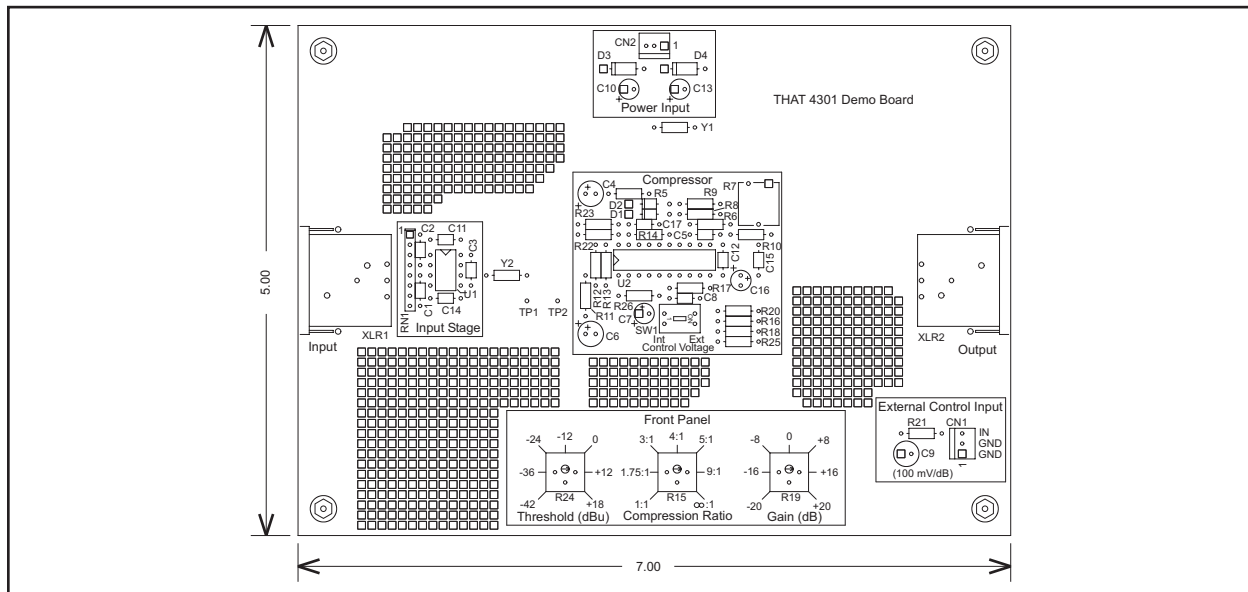

Figure 2. 4301-DEMO Outline Drawing

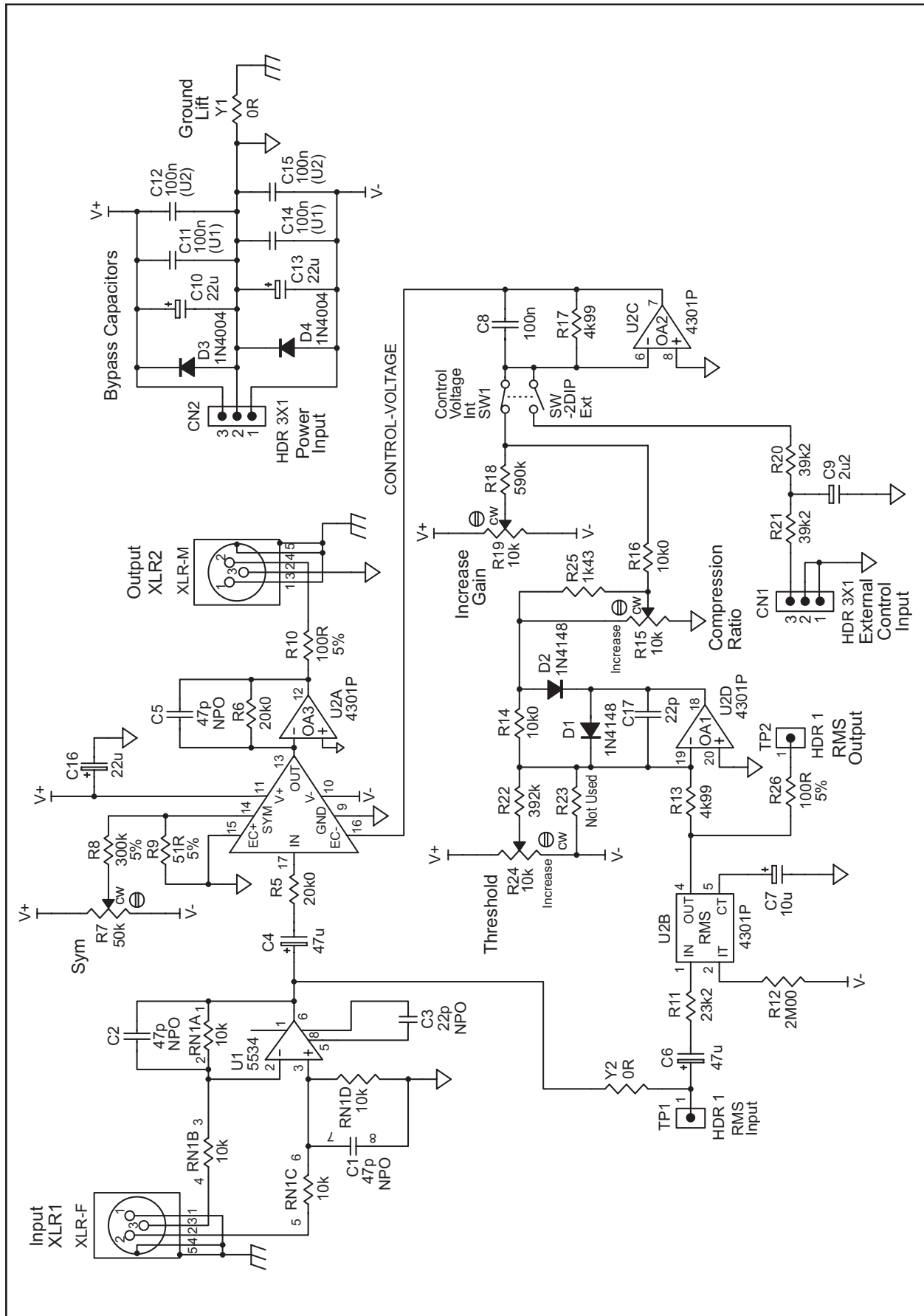

Figure 3. 4301 demo board schematic

Notes: