

FEATURES

- Allows Instant Product Evaluation
 - Preassembled and Pretested
- SIP Socket for THAT2181-Series VCAs
- XLR Input/Output Connectors
- Choice of On-Board or External Control Voltage Source
- Generous Prototyping Area
- Complete Documentation Package
 - Schematic and Assembly Drawing

APPLICATIONS

- Verification of 2181 Performance
- Comparison of 2181-Series Performance
- Prototyping VCA Circuits
- PCB Layout Reference Design

Description

The 2181 Demonstration Board is a self-contained circuit board that simplifies evaluating the performance of a 2181-Series Voltage Controlled Amplifier (VCA) IC. It features a simple signal path consisting of a differential input buffer, the VCA and the VCA's output current-to-voltage converter. Gain control voltage is supplied on the board, but may also be supplied externally. An external (± 15) power supply is required.

Completely assembled and tested, the 2181 Demonstration Board comes with XLR connectors for signal input, signal output and external con-

trol voltage input. A socket is provided for inserting your choice of 2181-Series VCAs. Power supply connections are made via a 3-pin 0.1-inch-center Molex connector.

To ease prototyping specific applications, spare circuit board area is perforated, with plated-through holes. This makes the board particularly useful for experimentation.

With a 2181 Demonstration Board and standard audio cables, an engineer can start testing the performance of basic 2181 circuitry in seconds, and can begin trying out additional circuit ideas in minutes.

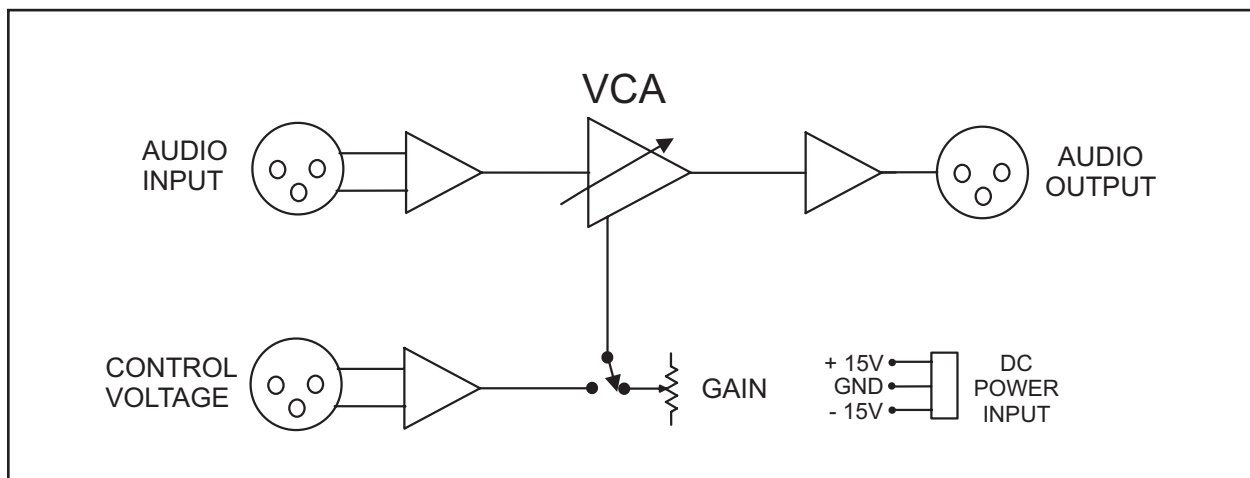

Figure 1. 2181-DEMO Block Diagram

SPECIFICATIONS¹

Absolute-Maximum Ratings ($T_A = 25^\circ\text{C}$)

Positive Supply Voltage (V_{CC})	+18 V	Operating Temperature Range (T_{OP})	0 to +70°C
Negative Supply Voltage (V_{EE})	-18 V	Storage Temperature Range (T_{ST})	0 to +100°C
External Control Voltage (V_C)	±12 V		

Typical Power Supply Requirements

Parameter	Symbol	Conditions	Min	Typ	Max	Units
Positive Supply Voltage	V_{CC}		+12	+15	+18	V
Negative Supply Voltage	V_{EE}		-18	-15	-12	V

Electrical Characteristics²

Parameter	Symbol	Conditions	Min	Typ	Max	Units
Gain Range		Internal Control	-100	-	+20	dB
		External Control	-120	-	+60	dB
Control Voltage Constant		External Control	88	100	112	mV/dB
Supply Current		±15 V Supply	-	28	40	mA
Input Impedance, Audio	Z_{IN}	Differential	19.6	20	20.4	kΩ
Input Impedance, Control	Z_{IN}	Differential	3.16	3.3	3.43	kΩ
Input Overload	$V_{IN(MAX)}$	$V_{CC} = -V_{EE} = 15V$	+18	+19	-	dBV
Output Impedance	Z_{OUT}	Single-ended	95	100	105	Ω
Minimum Resistive Load			600	-	-	Ω
Maximum Capacitive Load			-	-	1	nF
Dimensions				5x7x1.5		in
Weight				0.4		lb

1. All specifications subject to change without notice
2. Unless otherwise noted, $T_A = 25^\circ\text{C}$, $V_{CC} = +15V$, $V_{EE} = -15V$.

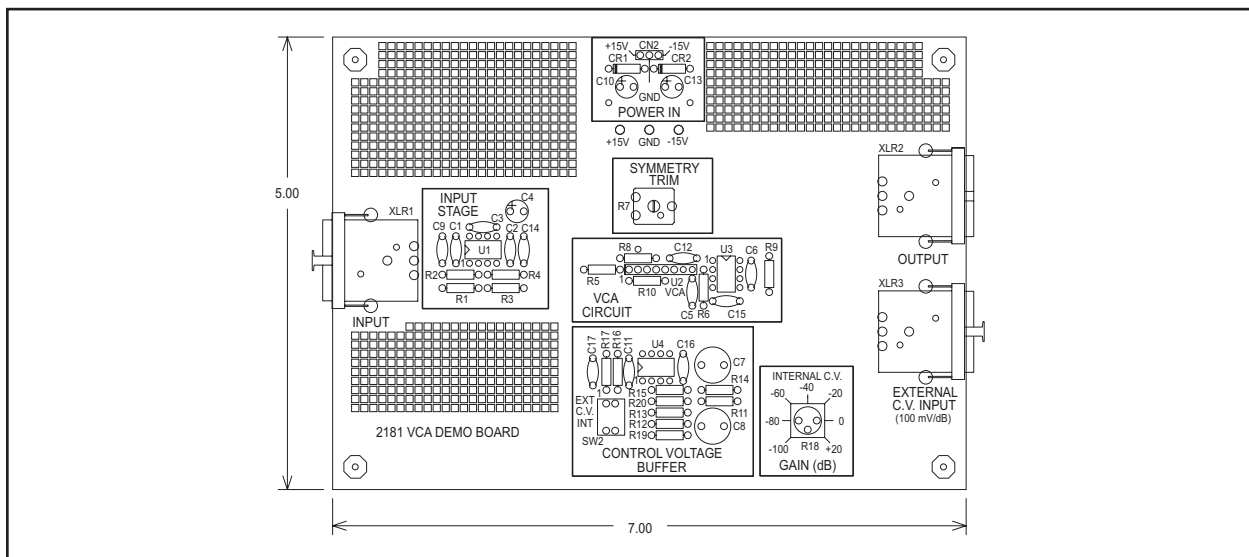

Figure 2. 2181-DEMO Outline Drawing